

HEADY

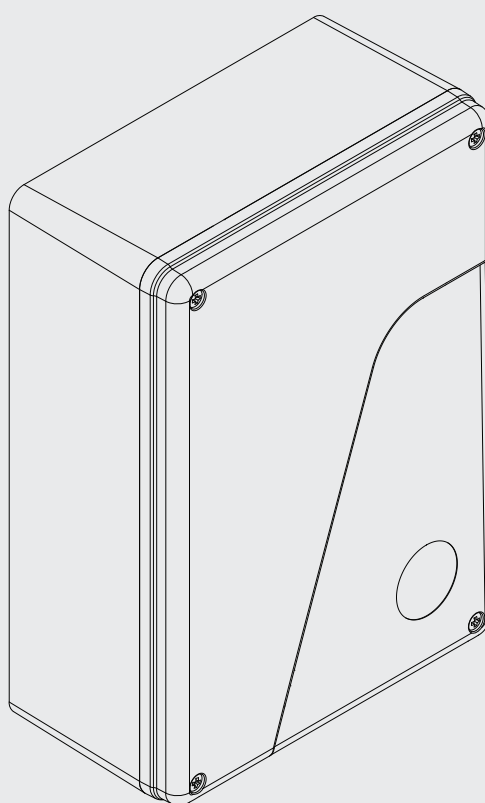

BENINCA[®]
TECHNOLOGY TO OPEN



Fig. 1 HEADY

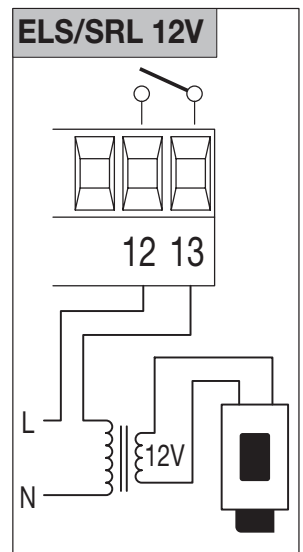
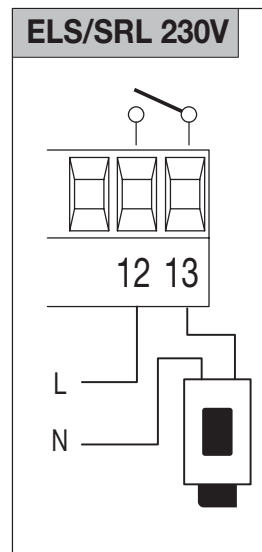
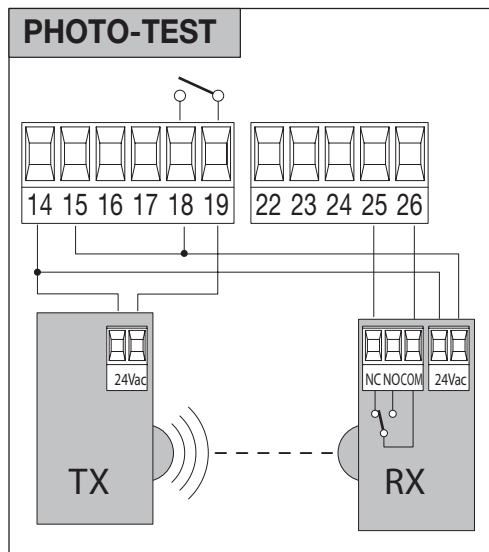
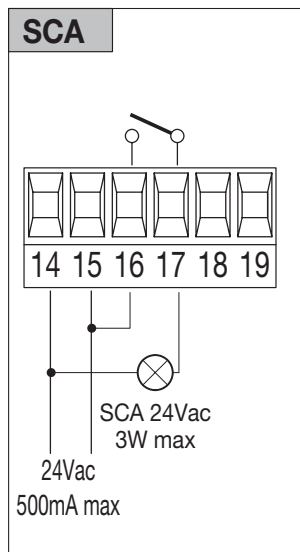
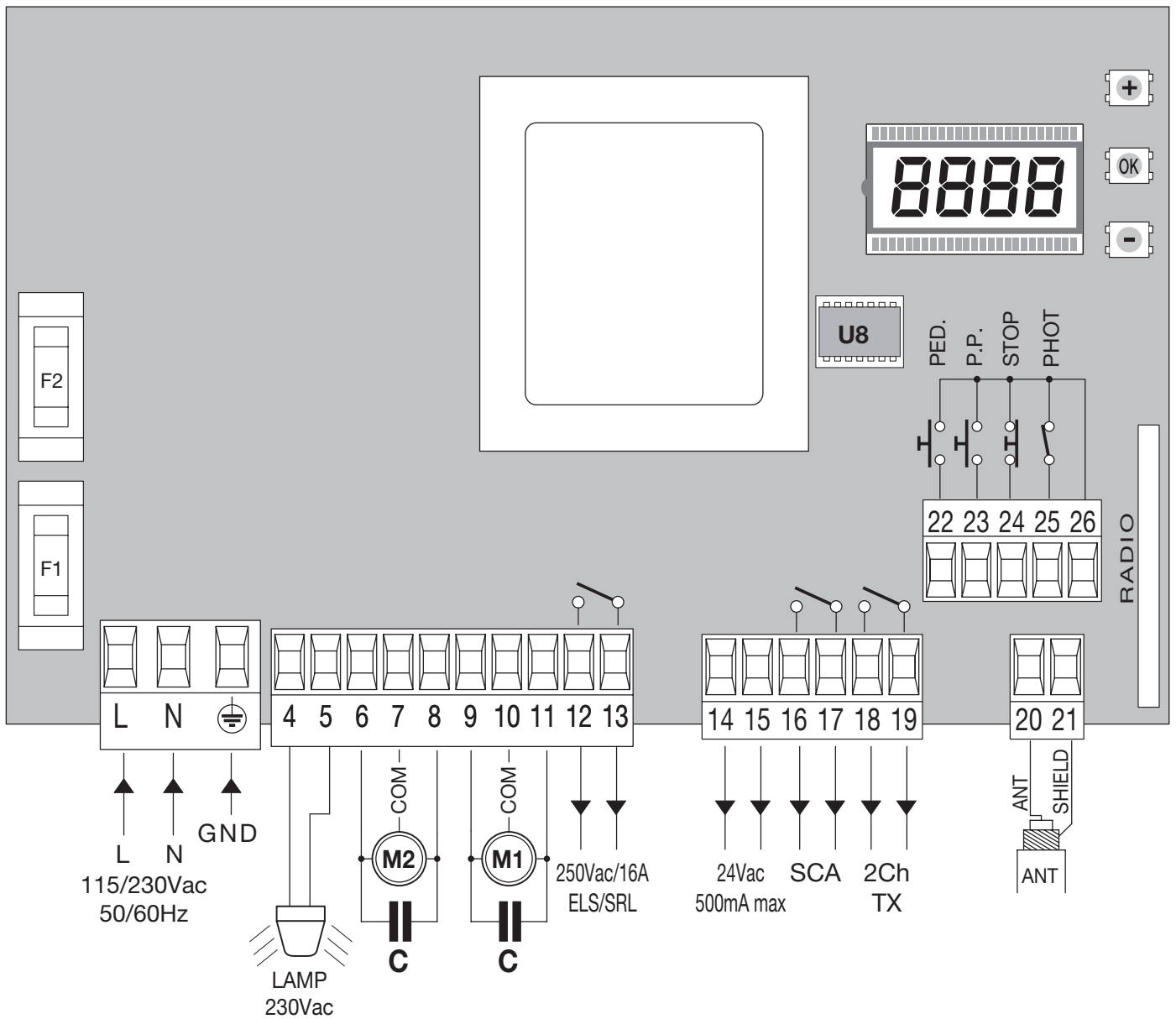

Code

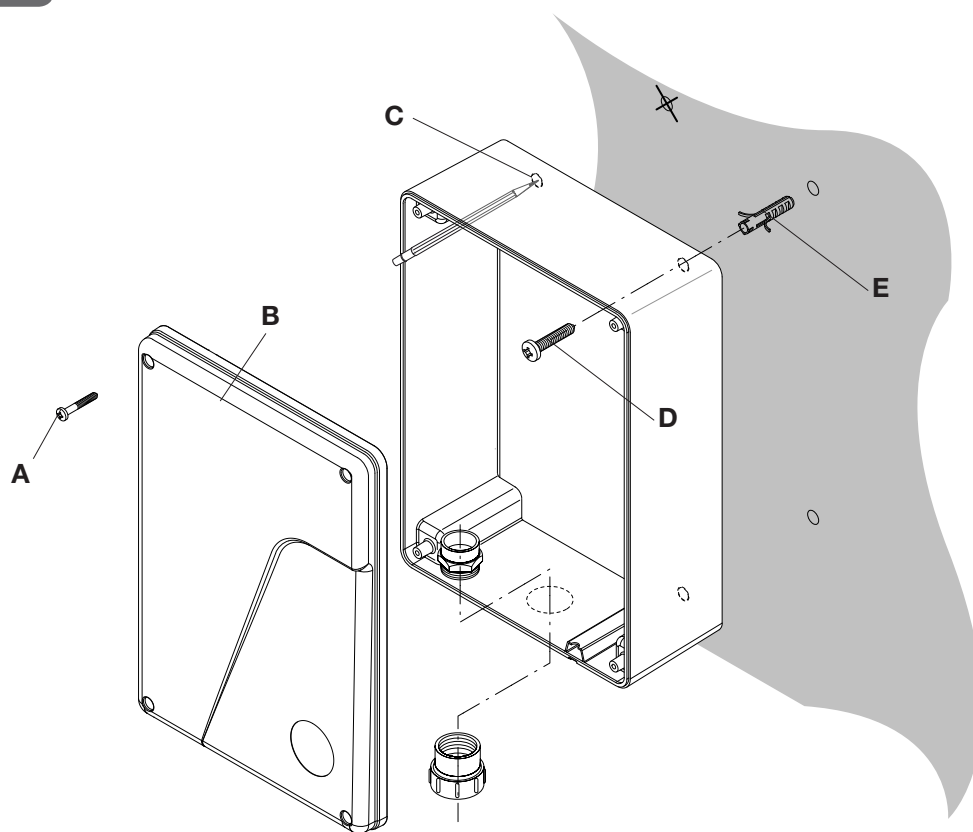

Rimuovere le 4 viti A , quindi rimuovere il coperchio B
 Sul fondo del contenitore centrale sono presenti 4 predisposizioni (C) da rompere con un cacciavite.
 Posare il fondo alla parete e segnare i 4 punti di foratura.
 Eseguire 4 fori ed inserire 4 tasselli (E), fissare la centrale con le 4 viti D. Tasselli e viti sono fornite in dotazione.

Remove the 4 screws A and then remove cover B
 There are 4 set-ups (C) present on the base of the control unit container, which must be broken using a screwdriver.
 Place the base on the wall and mark the 4 drilling points.
 Make the 4 holes and insert the 4 plugs (E), fix the control unit with the 4 screws D. Plugs and screws are supplied.

Entfernen Sie die 4 Schrauben A und nehmen Sie Deckel B ab.
 Im Boden des Hauptgehäuses befinden sich 4 vorbereitete Öffnungen (C), die mit einem Schraubenzieher aufzubrechen sind.
 Halten Sie den Boden an die Wand und zeichnen Sie die 4 Bohrungen an.
 Führen Sie die 4 Bohrungen aus und setzen Sie 4 Dübel (E) ein.
 Fixieren Sie die Steuerung mit den 4 Schrauben D. Dübel und Schrauben werden mitgeliefert.

Enlever les 4 vis A puis enlever le couvercle B
 Au fond du boîtier de la centrale se trouvent 4 ouvertures spéciales (C) qu'il faut creuser à l'aide d'un tournevis.
 Appuyer le fond du boîtier contre le mur et marquer avec 4 signes les points de perçage.
 Percer les 4 trous et insérer les 4 chevilles (E), fixer la centrale avec les 4 vis D. Les chevilles et les vis sont fournies en dotation.

Quite los 4 tornillos A, entonces quite la cubierta B
 En el fondo de la caja central hay 4 predisposiciones (C) que hay que romper con un destornillador.
 Apoye el fondo a la pared y marque los 4 puntos de perforación.
 Realice los 4 agujeros e introduzca los 4 tacos (E), fije la central con los 4 tornillos D. Se proporcionan los tacos y los tornillos.

Wykręć śruby A i ściągnij pokrywę B.
 Śrubokrętem zrób 4 otwory (C) na tylnej ścianie skrzynki. Przyłóż skrzynkę do ściany i zaznacz 4 miejsca na otwory. Wywierć otwory, wsadź 4 kołki (E), przykręć skrzynkę wkrętami (D).

EC Declaration of conformity

Declaration pursuant to Directives 2004/108/EC(EMC); 2006/95/EC(LVD)

Manufacturer:

Automatismi Benincà SpA

Address:

Via Capitello, 45 - 36066 Sandrigo (VI) - Italy

Declares that the product:

Command central for 1/2 230 Vac motor, for single or sliding doors: HEADY

is compliant with the conditions of the following EC Directives:

• **DIRECTIVE 2004/108/EC OF THE EUROPEAN PARLIAMENT AND COUNCIL** of December 15 2004 regarding the approximation of the legislations of the member States relative to electromagnetic compatibility and that repeals directive 89/336/CEE, according to the following concurred norms:

EN 61000-6-2:2005, EN 61000-6-3:2007.

• **DIRECTIVE 2006/95/EC OF THE EUROPEAN PARLIAMENT AND THE COUNCIL** of December 12 2006 concerning the approximation of the legislations of the member States relative to electrical material destined to be used within certain voltage limits, according to the following concurred regulations:

EN 60335-1:2002 + A1:2004 + A11:2004 + A12:2006 + A2:2006 + A13:2008; EN 60335-2-103:2003.

if applicable :

• **DIRECTIVE 1999/5/EC OF THE EUROPEAN PARLIAMENT AND THE COUNCIL** of March 9 1999 regarding radio devices and terminal and telecommunications devices and the reciprocal recognisances of their conformity, according to the following concurred regulations: ETSI EN 301 489-3 V1.4.1 (2002) + ETSI EN 301 489-1 V1.4.1 (2002) + ETSI EN 300 220-3 V1.1.1 (2000) + EN 60950-1 (2001)

Benincà Luigi, Legal manager.

Sandrigo, 02/11/2010.

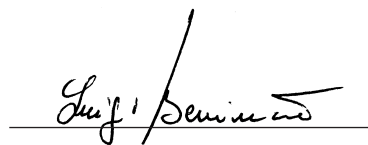

WARNINGS

This manual has been especially written to be use by qualified fitters.

None of the information provide in this manual can be considered as being of interest for the end users.

Preserve this manual for future needs.

The technician has to furnish all the information related to the step by step function, the manual and the emergency function of the operator, and to deliver the manual to the final user.



Foresee on the supply net an onnipolar switch or selector with distance of the contacts equal or superior to 3 mms.

Verify that of the electrical system there is an awry differential interrupter and overcurrent protection.

Some typologies of installation require the connection of the shutter to be link at a conductive mass of the ground according to the regulations in force.

The electrical installation and the operating logic must comply with the regulations in force.

The leads fed with different voltages must be physically separate, or they must be suitably insulated with additional insulation of at least 1 mm.

The leads must be secured with an additional fixture near the terminals.

During installation, maintenance and repair, interrupt the power supply before opening the lid to access the electrical parts

Check all the connections again before switching on the power.

The unused N.C. inputs must be bridged.

The descriptions and the present illustrations in this manual are not binding. Leaving the essential characteristics of the product unchanged, the manufacturer reserves himself the right to bring any change of technical, constructive or commercial character without undertaking himself to update the present publication.

TECHNICAL DATA

Mains power supply	230 VAC 50/60 Hz (115VAC 50/60 Hz for HEADY 115)
Output, Motor	1/2 motor 230VAC (115V for HEADY 115)
Motor maximum power	500W + 500W
Output, power supply of accessories	24VDC 500mA max.
Protection level	IP54
Operating temperature	-20°C / +70°C
Radio receiver	433,92 MHz, incorporated and configurable
No. of codes storable in memory	64

HEADY CONTROL UNIT

INPUT/OUTPUT FUNCTIONS

Terminals	Function	Description
L-N-GND	Power supply	Input, mains power supply. HEADY:230VAC 50/60Hz (/1-Phase/2-Neutral 3-GND) HEADY115: HEADY:230VAC 50/60Hz (/1-Phase/2-Neutral 3-GND)
4-5	Flashing light	Connection of flashing light, 230VAC 40W max, or 115VAC 40W max, for HEADY 115.
6-7-8	Motor 2	Connection to motor 2: 6-move/7-Com/8-move)
9-10-11	Motor 1	Connection to motor 1: 9-move/10-Com/11-move)
12-13	ELS/SRL	Normally Open free tension contact for courtesy light or electric lock See TLS parameter
14-15	24 VAC	Output, power supply of accessories, 24VAC/0.5A max
16-17	SCA	N.O. free-tension contact for open gate warning light With open gate the contact is closed, flashing light during operation and open contact with closed gate.
18-19	2CH/TX.	Output, second radio channel of the integrated receiver or photocell power supply in photo test mode. N.O. tension-free contact. See wire diagram, Fig 1.
20-21	Antenna	Connection of extractable radio receiver card to antenna (20-signal/21-monitor).
22	PED	Input, push-button for pedestrian opening (Normally Open contact) The total opening of motor 1 is carried out.
23	Step-by-Step	Input, Step-by-Step push-button (Normally Open contact) See P.P. Logics
24	STOP	Input, STOP push-button (Normally Closed contact)
25	PHOT	Input, photocell active in the opening and/or closing phase (Normally Closed contact) See PHCL Logics
26	COM	Common, for control inputs.

FUSES

F1: F6.3A (230VAC) / F10A (115VAC) – Motor protection

F2: T315mA (230VAC) - T500mA (115VAC) – Protection for primary transformer

TO CHECK CONNECTIONS:

- 1) Cut-off power supply.
- 2) Manually release the wings, move them to approx. half-stroke and lock them again.
- 3) Reset power supply.
- 4) Send a step-by-step control signal by pressing the button ->.
- 5) The wings should start an OPENING movement.

If this is not the case, invert the movement wires of the motor (9<>11 for motor M1, and 6<>8 for motor M2).

PROGRAMMING

The programming of the various functions of the control unit is carried out using the LCD display on the control unit and setting the desired values in the programming menus described below.

The parameters menu allows you to assign a numerical value to a function, in the same way as a regulating trimmer.

The logic menu allows you to activate or deactivate a function, in the same way as setting a dip-switch.

Other special functions follow the parameters and logic menus and may vary depending on the type of control unit or the software release.

TO ACCESS PROGRAMMING

- 1 – Press the button <PG>, the display goes to the first menu, Parameters “PAR”.
- 2 – With the <+> or <-> button, select the menu you want.
- 3- Press the button <PG>, the display shows the first function available on the menu.
- 4 - With the <+> or <-> button, select the function you want.
- 5 - Press the button <PG>, the display shows the value currently set for the function selected.
- 6 - With the <+> or <-> button, select the value you intend to assign to the function.
- 7 - Press the button <PG>, the display shows the signal “PRG” which indicates that programming has been completed.

NOTES

Simultaneously pressing <+> and <-> from inside a function menu allows you to return to the previous menu without making any changes.

Simultaneously pressing <+> and <-> when the display is switched off shows the card software release.

Hold down the <+> key or the <-> key to accelerate the increase/decrease of the values.

After waiting 30s the control unit quits programming mode and switches off the display.

PARAMETERS, LOGIC AND SPECIAL FUNCTIONS

The tables below describe the individual functions available in the control unit.

PARAMETERS (PR_r)			
MENU	FUNCTION	MIN-MAX-(Default)	MEMO
t _{cA}	Automatic closing time. Active only with logic “TCA”=ON. At the end of the set time the control unit orders a closing manoeuvre.	1-240-(40s)	
t _{n1}	Motor 1 work time. Regulates the maximum duration of the opening and closing manoeuvre of the motor 1. It must be set about 4 sec. longer than the actual travel time of the automatism.	5-180-(24s)	
t _{n2}	Motor 2 work time. Regulates the maximum duration of the opening and closing manoeuvre of the motor 2. It must be set about 4 sec. longer than the actual travel time of the automatism.	5-180-(24s)	
t _{dno}	Mot.2 opening delay time. Regulates the delay time of motor 2 on opening with respect to motor 1	0-15-(2s)	
t _{dn1}	Mot.1 closing delay time Regulates the delay time of motor 1 on closing with respect to motor 2	0-40-(3s)	
p _{n1}	Torque of Motor 1. The torque applied to motor 1 is adjusted. COMPLY WITH REGULATIONS IN FORCE! <i>In oil-hydraulic motors, regulate unit to maximum value (99). Use the by-pass valves to adjust the applied torque.</i>	1-99-(40%)	
p _{n2}	Torque, Motor 2. The torque applied to motor 2 is adjusted. COMPLY WITH REGULATIONS IN FORCE! <i>In oil-hydraulic motors, regulate unit to maximum value (99). Use the by-pass valves to adjust the applied torque.</i>	1-99-(40%)	
p _{s1}	The torque applied to motor 1 during braking in the opening and closing phase is adjusted. COMPLY WITH REGULATIONS IN FORCE	1-99-(70%)	
p _{s2}	The torque applied to motor 2 during braking in the opening and closing phase is adjusted. COMPLY WITH REGULATIONS IN FORCE!	1-99-(70%)	
t _{LS}	ELS/SRL contact activation time. At the beginning of each single operation, the contact closes for the preset time. If it is preset on 0, it has the service light function. The contact remains closed when the motor is moving or is in TCA dwell time and it opens when the motor is stopped.	0-240-(90s)	

LOGIC (Lo_U)			
MENU	FUNCTION	ON-OFF-(Default)	MEMO
t _{cA}	Enables or disables automatic closing On: automatic closing enabled Off: automatic closing disabled	(ON)	
i _{bL}	Enables or disables condominium function. Off: condominium function disabled. On: condominium function enabled. The step-by-step impulse or transmitter impulse has no effect during the opening phase.	(OFF)	

SCL	Enables or disables rapid closing On: rapid closing enabled. With the gate open or in the opening phase the intervention of the photocell causes automatic closing after 3 s. Active only with TCA:ON. Off: rapid closing disabled.	(OFF)	
SLD	Braking is enabled or disabled. On: Braking activated. Braking starts around 7 seconds before the end of the operating time preset with TM1/TM2 parameters. Off: Braking excluded.	(OFF)	
PP	Selects the operating mode of the "Step by step button" and of the transmitter. On: Operation: OPEN > CLOSE > OPEN > Off: Operation: OPEN > STOP > CLOSE > STOP >	(OFF)	
PrE	Enables or disables pre-blinking. On: Pre-blinking enabled. Blinking is activated 3s before the motor starts. Off: Pre-blinking disabled.	(OFF)	
hRN	The reversion function is enabled or disabled. On: Enabled function. Before every opening or closing operations, the control unit control a 2sec operation in the opposite direction to facilitate the release of the electric lock. Off: Disabled function.	(OFF)	
SPn	The pickup function is enabled or disabled. On: Enabled pickup. At the beginning of every operation, the motor operates at maximum torque for 2 sec. Off: Disabled pickup.	(ON)	
INot	Select the 1/2 motors operating mode: On: only one motor (motor 1) active. Function to be used in the following cases: - for single motor, to connect M1. - for two synchronized motors (for instance overhead door), to connect M1 and M2. Off: Both motors operating.	(OFF)	
cuAr	The code programmable transmitters is enabled or disabled. On: Radio receiver enabled only for rolling-code transmitters. Off: Receiver enabled for rolling-code and programmable code transmitters (self-learning and Dip Switch).	(OFF)	
PHtC	The operating mode of the PHOT C input is selected. On: The PHOT C input is activated in the closing phase only. In the closing phase: the contact opening causes the motor stop and the immediate reversion of the operation direction (open). Off: PHOT C input is activated in both opening and closing phases. In the opening phase: the contact opening causes the motor stop. When the photocell is released, the motor restarts in the opening phase. In closing phase: the contact opening causes the motor stop. When the photocell is released, the motor inverts the movement direction (open).	(OFF)	
oPCL	PP input as OPEN and PED input as CLOSED are enabled or disabled. On: PP input is enabled as OPEN and PED input is enabled as CLOSED. Off: PP and PED inputs are enabled with their function.	(OFF)	
2ch	It selects the operating mode of the 2CH/TX output. On: The output is controlled by the second radio channel of the incorporated receiver. See "RADIO" menu to store the transmitter codes. Off: The output is configured for the connection of photocells in test mode (see Fig.1).	(OFF)	
bb	The thrust function in the closing phase is activated or deactivated by this logic. With SLD logic only: ON On: the operation in the closing phase is carried out at normal speed during the last second (braking is disabled). In this way, a better hooking of the electric lock is performed. Off: disabled function.	(OFF)	
SErL	The bistable operation of ELS/SRL output (terminals 12-13) matched to the 2nd radio channel is enabled or disabled. On: bistable operation of the ELS/SRL output activated. The output to terminals 12-13 is activated/deactivated through the activation of the 2nd radio channel. OFF: normal operation of the ELS/SRL output based on the TLS parameter.	(OFF)	
rEN	The remote storage of the radio transmitter codes is enabled or disabled (see par. REMOTE LEARNING). On: Enabled remote storage Off: Disabled remote storage.	(ON)	

RADIO (rAd)

MENU	FUNZIONE
PP	By selecting this function, the receiver is waiting for (Push) a transmitter code to be assigned to the step-by-step function. Press the transmitter key, which is to be assigned to this function. If the code is valid, it will be stored in memory and OK will be displayed. If the code is not valid, the Err message will be displayed.
2ch	By selecting this function, the receiver is waiting for (Push) a transmitter code to be assigned to the second radio channel. Press the transmitter key, which is to be assigned to this function. If the code is valid, it will be stored in memory and OK will be displayed. If the code is not valid, the Err message will be displayed.
PEd	When this function is selected, the receiver awaits (Push) a transmitter code to be assigned to the pedestrian function. Press the transmitter key, which is to be assigned to this function. If the code is valid, it will be stored in memory and OK will be displayed. If the code is not valid, the Err message will be displayed.
cLr	By selecting this function, the receiver is waiting for (Push) a transmitter code to be erased from memory. If the code is valid, it will be stored in memory and OK will be displayed. If the code is not valid, the Err message will be displayed.
rEr	The memory of the receiver is entirely erased. Confirmation for the operation is asked. By selecting this function, the receiver waits for (Push) the GPM key to be pressed again to confirm the operation. At end of erasing, the OK message is displayed

RESET (rE5)

RESET of the control unit. ATTENTION!: Returns the control unit to the default values.
Pressing the <PG> button for the first time causes blinking of the letters RES, pressing the <PG> button again resets the control unit.

CYCLES NUMBER (nAn)

Displays the number of complete cycles (open+close) carried out by the automation.
When the <PG> button is pressed for the first time, it displays the first 4 figures, the second time it shows the last 4. Example <PG> 00 12 >>> <PG> 3456: made 123.456 cycles.

PROTECTION CODE (codE)

It allows to type in an access protection code to the programming of the control unit.
A four-character alphanumeric code can be typed in by using the numbers from 0 to 9 and the letters A-B-C-D-E-F.
The default value is 0000 (four zeros) and shows the absence of a protection code.
By replacing the 0000 code with any other code, the protection of the control unit is enabled, thus preventing the access to any other menu. If a protection code is to be typed in, proceed as follows:

- select the Code menu and press OK.
- the code 0000 is shown, also in the case a protection code has been previously typed in.
- the value of the flashing character can be changed with keys + and -.
- press OK to confirm the flashing character, then confirm the following one.
- after typing in the 4 characters, a confirmation message "CONF" appears.
- after a few seconds, the code 0000 appears again
- the previously stored protection code must be reconfirmed in order to avoid any accidental typing in.

If the code corresponds to the previous one, a confirmation message "OK" appears.
The control unit automatically exits the programming phase. To gain access to the Menus again, the stored protection code must be typed in.
While typing in the code, this operation can be cancelled at any moment by pressing keys + and - simultaneously. Once the password is typed in, it is possible to act on the control unit by entering and exiting the programming mode for around 10 minutes in order to allow adjustments and tests on functions.

IMPORTANT: TAKE NOTE of the protection code and KEEP IT IN A SAFE PLACE for future maintenance operations. To remove the code from a protected control unit, it is sufficient to reset the code to the 0000 default value.

IF YOU LOOSE THE CODE, PLEASE CONTACT THE AUTHORISED SERVICE CENTER FOR THE TOTAL RESET OF THE CONTROL UNIT.

LCD DISPLAY

If the control unit must be turned to allow for the passage of cables, the LCD display can be turned by 180°.

- Cut off mains power supply
- Press PGM
- While keeping PGM pressed, reset the mains power supply
- Keep PGM pressed (around 5 sec) until the software version appears, turned by 180°.

Normally proceed with programming.

ERROR MESSAGES

ERR1: Error, photocells, presence of an obstacle or non-powered photocells.

TRANSMITTER REMOTE LEARNING

If the transmitter code is already stored in the receiver, the remote radio learning can be carried out (without accessing the control unit).

IMPORTANT: The procedure should be carried out with gate in the opening phase, during the TCA dwell time.

Proceed as follows:

- 1 Press the hidden key of the transmitter, the code of which has already been stored in memory.
- 2 Within 5 seconds, press the already memorised transmitter key corresponding to the channel to be matched to the new transmitter. The flashing light switches on.
- 3 Within 10 seconds, press the hidden key of the new transmitter.
- 4 Within 5 seconds, press the key of the new transmitter to be matched to the channel selected at item 2. The flashing light switches off.
- 5 The receiver stores the new transmitter code and exits from the programming mode immediately.

DIAGNOSTICS

In the event of malfunctions, by pressing key + or - the status of all inputs (limit switches, control and safety) can be displayed. One segment of the display is linked to each input. In the event of failure it switches on according to the following scheme.

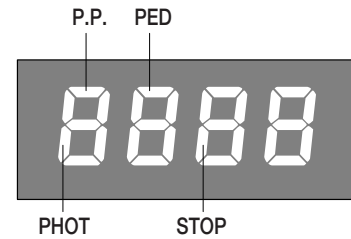

WASTE DISPOSAL

If the product must be dismantled, it must be disposed according to regulations in force regarding the differentiated waste disposal and the recycling of components (metals, plastics, electric cables, etc..).

For this operation it is advisable to call your installer or a specialised company.